

# Indoor Unit Operation & Installation Manual

AD072MQERA

AD092MQERA

AD122MQERA

AD152MQERA

AD182MQERA

AD242MQERA

AD282MQERA

AD302MQERA

AD362MQERA

AD422MQERA

AD482MQERA

AD542MQERA

- Please read this manual carefully before using
- Keep this operation manual for future reference

Original instructions

# User Manual

Your air conditioner may be subject to any change owing to the improvement of Haier products.

MRV series multiple air conditioner systems adopt the consistent running mode, by which, all indoor units can only be heating or refrigerating operation at the same time.

To protect the compressor, the air conditioner unit should be powered on for over 12 hours before using it.

All indoor units of the same refrigerating system should use the unified power switch to ensure that all indoor units are in the state of being powered on at the same time during the operation of air conditioner.

## Contents

Parts and Functions.....	1
Safety .....	2
Maintenance .....	4
Fault Checkup.....	5
Installation Procedures.....	6
Electrical Wiring .....	14
Test Run & Fault Code .....	20

## Warning

- If the supply cord is damaged, it must be replaced by the manufacturer, its service agent or similarly qualified persons in order to avoid a hazard.
- This appliance is not intended for use by persons (including children) with reduced physical, sensory or mental capabilities, or lack of experience and knowledge, unless they have been given supervision or instruction concerning use of the appliance by a person responsible for their safety.
- Children should be supervised to ensure that they do not play with the appliance.
- This appliance can be used by children aged from 8 years and above and persons with reduced physical, sensory or mental capabilities or lack of experience and knowledge if they have been given supervision or instruction concerning use of the appliance in a safe way and understand the hazards involved. Children shall not play with the appliance. Cleaning and user maintenance shall not be made by children without supervision.
- The appliances are not intended to be operated by means of an external timer or separate remote-control system.
- Keep the appliance and its cord out of reach of children less than 8 years.

## Product Features

- 1.Function of central control (optional from our company);
- 2.Automatic display of fault detection;
- 3.The air conditioner is provided with the function fo compensation for power supply.During operation, when the power supply fails emergently and resumes again,the air conditioner returns to the working condition before power failure,if provided with compensation function.
- 4.Now this indoor unit only has wired controller function,the indoor unit that has remote controller function need to set in factory especially.

## Operating Range of Air Conditioner

cooling	indoor	max.	DB: 32°C WB: 23°C
		min.	DB: 18°C WB: 14°C
dry	outdoor	max.	DB: 43°C WB: 26°C
		min.	DB: -5°C
heating	indoor	max.	DB: 27°C
		min.	DB: 15°C
	outdoor	max.	DB: 21°C WB: 15°C
		min.	DB: -15°C

# Parts and Functions



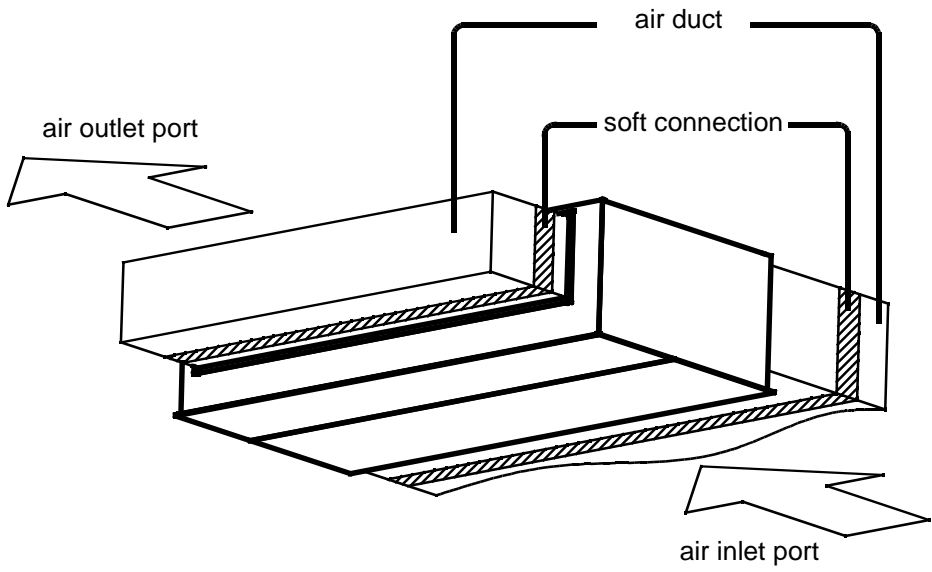

---

indoor unit



# Safety

---

- If the air conditioner is transferred to a new user, this manual shall be transferred to the user, together with the conditioner.
- Before installation, be sure to read Safety Considerations in this manual for proper installation.
- The safety considerations stated below is divided into “ Warning” and “ Attention”. The matters on severe accidents caused from wrong installation, which is likely to lead to death or serious injury, are listed in “ Warning”. However, the matters listed in “ Attention” are also likely cause the severe accidents. In general, both of them are the important items related to the security, which should be strictly abided by.
- After the installation, perform test run to make sure everything is in normal conditions, and then operate and maintain the air conditioner in accordance with the User Manual. The User Manual should be delivered to the user for proper keeping.

## Warning

- Please ask the special maintenance station for installation and repair. Water leakage, electric shocks or fire accidents might be caused from improper installation if you conduct the installation by your own.
- The installation should be conducted properly according to this manual. Water leakage, electric shocks or fire accidents might be caused from improper installation.  
Please make sure to install the air conditioner on the place where can bear the weight of the air conditioner.
- The air conditioner can't be installed on the grids such as the non-special metal burglar-proof net. The place with insufficient support strength might cause the dropdown of the machine, which may lead to personal injuries.
- The installation should be ensured against typhoons and earthquakes, etc. The installation unconfomable to the requirements will lead to accidents due to the turnover of the machine.
- Specific cables should be used for reliable connections of the wirings. Please fix the terminal connections reliably to avoid the outside force applied on the cables from being impressed on the cables. Improper connections and fixings might lead to such accidents as heating or fire accidents.
- Correct shapes of wirings should be kept while the embossed shape is not allowed. The wirings should be reliably connected to avoid the cover and the plate of the electrical cabinet lipping the wiring. Improper installation might cause such accidents as heating or fire accidents.
- While placing or reinstalling the air conditioner, except the specific refrigerant (R410A), don't let the air go into the refrigeration cycle system. The air in the refrigeration cycle system might lead to the cracking or personal injuries due to abnormal high pressure of the refrigeration cycle system.
- During installation, please use the accompanied spare parts or specific parts. If not, water leakage, electric shocks, fire accidents or refrigerant leakage might be caused.
- Don't drain the water from the drainpipe to the waterspout where may exist harmful gases such as sulfureted gas to avoid the harmful gases entering into the room.
- During installation, if refrigerant leakage occurs, ventilation measures should be taken, for the refrigerant gas might generate harmful gases upon contacting the flame.
- After installation, check if any refrigerant leakage exists. If the refrigerant gas leaks in the room, such things as air blowing heaters and stoves, etc. may generate harmful gases.
- Don't install the air conditioner at the places where the flammable gases may leak. In case the gas leakage occurs around the machine, such accidents as fire disasters may be caused.
- The drainpipe should be properly mounted according to this manual as to ensure the smooth drainage. In addition, heat preservation should be taken to avoid condensation. Improper drainpipe mounting might cause water leakage, which will get the articles at home wet.
- The refrigerant gas pipe and liquid pipe should be heat insulated to preserve heat. For inappropriate heat insulation, the water caused from the condensation will drop to get the article at home wet.

## Attention

- The air conditioner should be effectively grounded. Electric shocks may occur if the air conditioner is ungrounded or inappropriately grounded. The wire for earthing shouldn't be connected to the connections on the gas pipe, water pipe, lightning rod or telephone.
- The breaker for electricity leakage should be mounted. If not, accidents such as electric shocks may happen.
- The installed air conditioner should be checked for electricity leakage by being powered.
- If the ambient humidity bigger than 80%, when the water discharge hole be blocked or the filter becomes dirty, or airflow speed change, there maybe leads to condensing water drop down, and at the same time there maybe some drops of water spit out.

# Safety

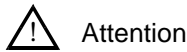

Attention

Notices during Operation

- It is not allowed to put any heating apparatus under the indoor units, for the heat may cause distortion of the units.

- Pay attention to the aeration condition to avoid anoxic symptom.

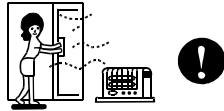

- Flammable apparatus should not be placed in the place where the air conditioner wind could reach directly, or incomplete burning of the apparatus may be caused.



- Check the mount table of the air conditioner for damage for a long period of operation. If placed on the damaged table, the unit may drop down causing damage.

- Plants and animals should not be put to the place where wind of the air conditioner blows directly, otherwise damage to them may be caused.

- It cannot be used for the preservation of food, living creature, precise instrument and artworks, etc, otherwise damage may occur.

- Use the fuse with proper capacity. Metal wires and copper wires, etc., may cause fire or other faults.

- Do not use water heater or like next to the indoor unit and the wired controller. Water/power leakage or short circuit may happen if the steam generating apparatus is working next to machine.

- Defrosting during heating  
To improve the heating effect, the outdoor unit will perform defrosting automatically when frost appears on the outdoor unit during heating (approximately 2-10 min). During defrosting, the fan of the indoor unit runs at a low speed or stops while that of the outdoor unit stops running.

- Power should be cut off when the air conditioner is left unused for a long period. Power will be consumed if the air conditioner is not powered off. The power switch of the outdoor unit switch should be powered on 12 hours in advance before operation to protect the unit after a long period of storage.

- 3-minute protection  
To protect the unit, compressor can be actuated with at least 3-minute delay after stopping.

- Close the window to avoid outdoor air getting in. Curtains or window shutters can be put down to avoid the sunshine.

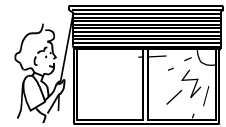

- Do not touch the switch with the wet hand to avoid power shock.

- Stop running and switch off the manual power switch when cleaning the unit.

- During the operation of the control unit, don't switch off the manual power switch and the controller can be used. Please do not press the liquid crystal zone of controller to prevent damage.

- Cleaning the unit with water may cause electric shock.



- Do not put flammable spray close to the air conditioner. Don't inject flammable spray towards the air conditioner, which may cause fire.

- Stopping fan rotation  
The unit which stops operating will actuate the fan for a 2-8 min swing every 30-60 minutes for protecting the unit while other indoor unit are in the operating state.

- This appliance is not intended for use by persons (including children) with reduced physical, sensory or mental capabilities, or lack of experience and knowledge, unless they have been given supervision or instruction concerning use of the appliance by a person responsible for their safety.

- Children should be supervised to ensure that they do not play with the appliance.

# Maintenance

※Only when the air cleaner is switched off and disconnected to the power supply can it be cleaned, or electric shock and injury may appear.

## Cleaning the air outlet port and the shell:

⚠ Attention

- Don't use gasoline, benzene, diluents, polishing powder or liquid insecticide to clean them.
- Do not clean them with hot water of above 50°C to avoid fading or distorting.
- Wipe them with soft dry cloth.
- Water or neutral dry cleanser is recommended if the dust cannot be removed.
- The Wind Deflector can be dismantled to clean (as below).

## Cleaning Wind Deflector:

- Do not wipe the wind deflector with water forcibly to avoid falling off.

## Cleaning Air Cleaner:

⚠ Attention

- Don't rinse the air cleaner with hot water of above 50°C to avoid fading and distorting.
- Don't put the air cleaner on the fire to dry to avoid catching fire.

- Wipe dust with water or dust collector.

(A) Wipe dust with dust collector.



(B) Clean it with soft brush in mild detergent if there is too much dust on it

Throw off the water and airing it in the cool dry condition.



## Maintenance before and after Operating Season

### Before Operating Season:

1. Please make the following checkup. If abnormal condition occurs, consult the after-service personnel.
  - There is no blockage in inlet port and outlet port of outdoor and indoor units.
  - The ground line and the wiring are in the proper state
2. After cleaning, the air cleaner must be mounted.
3. Switch on to the power.

### After Operating Season:

1. In sunny days, blowing operation can be performed for half a day to make the inside of machine dry.
2. Electrical power should be cut down to economize electricity, or the machine will still consume power. Air cleaner and shell must be mounted after cleaning.

# Fault Checkup

Please check the following when consigning repair service:

	Symptoms	Reasons
All these are not problems	<ul style="list-style-type: none"> <li>Water flow sound</li> </ul>	Water flow sound can be heard when starting operation, during operation or immediately after stopping operation. When it starts to work for 2-3 minutes, the sound may become louder, which is the flowing sound of refrigerant or the draining sound of condensed water.
	<ul style="list-style-type: none"> <li>Cracking sound</li> </ul>	During operation, the air conditioner may make the cracking sound, which is caused from the temperature changes or the slight dilation of heat exchanger.
	<ul style="list-style-type: none"> <li>Terrible smell in outlet air</li> </ul>	The terrible smell, caused from walls, carpet, furniture, clothing, cigarette and cosmetics, attaches on the conditioner.
	<ul style="list-style-type: none"> <li>Flashing operating indicator</li> </ul>	When switching it on again after power failure, turn on the manual power switch and the operating indicator flashes.
	<ul style="list-style-type: none"> <li>Awaiting indication</li> </ul>	It displays the awaiting indication as it fails to perform refrigerating operation while other indoor units are in heating operation. When the operator set it to the refrigerating or heating mode and the operation is opposite to the setting, it displays the awaiting indication.
	<ul style="list-style-type: none"> <li>Sound in shutdown indoor unit or white steam or cold air</li> </ul>	To prevent oil and refrigerant from blocking the shutdown indoor units, refrigerant flows in the short time and make the sounds of refrigerant flowing. Otherwise, when other indoor units performs heating operation, white steam may occur; during refrigerating operation, cold air may appear.
	<ul style="list-style-type: none"> <li>Clicking sound when switching the air condition on</li> </ul>	When the conditioner is powered on, the sound is made due to the resetting of the expansion valve.
Please make another check.	<ul style="list-style-type: none"> <li>Start or stop working automatically</li> </ul>	Check if it is in the state of Timer-ON and Timer-OFF.
	<ul style="list-style-type: none"> <li>Failure to work</li> </ul> 	Check if there is a power failure. Check if the manual power switch is turned off. Check if the supply fuse and breaker are disconnected. Check if the protective unit is working. Check if refrigerating and heating functions are selected simultaneously with the awaiting indication on line control.
	<ul style="list-style-type: none"> <li>Bad cooling &amp; heating effects</li> </ul>	Check if air intake port and air outlet port of outdoor units are blocked. Check if the door and windows are open. Check if the filtering screen of air cleaner is blocked with sludge or dust. Check if the setting of wind quantity is at low wind. Check if the setting of operation is at the Fan Operation state. Check if the temperature setting is proper.

Under the following circumstances, immediately stop the operation, disconnect the manual supply switch and contact the after-service personnel.

- When buttons are inflexible actuated;
- When fuse and breaker have been burnt over and over;
- When there are foreign objects and water in the refrigerator;
- When it cannot still be operated after removing the operation of protective unit;
- When other abnormal conditions occur.

# Installation Procedures

The standard attached accessories of the units of this series refer to the packing; prepare other accessories according to the requirements of the local installation point of our company.

## 1. Before installation [before finishing the installation, don't throw away the attached parts required for the installation]

- Determine the route to move the unit to the installation site;
- Don't tear the package open before moving the unit to the installation site. When unpacking is needed, a soft material or protector block with ropes can be used to lift the unit to avoid damaging or scraping of the unit.

## 2. Select the installation site

(1) The installation site should be selected according the following conditions, which should be approved by users.

- where an ideal air distribution can be ensured;
- where there is no blockage in the air passage;
- where the condensed water can be drained out properly;
- where the strength can bear the weight of the indoor unit;
- where enough space can be ensured for maintenance. The outside air should be input from the outdoor directly from the blast pipe. If the blast pipe can't be jointed, the air can't be input from the suspended ceiling.
- where the lengths of the piping between indoor units and outdoor units are within the allowable range (refer to Installation of Outdoor Units)
- where the distance of at least 1m between indoor units, outdoor units, mains supply, connecting wires and television or radio should be kept as to avoid the image disturbance and noises of the above electrical appliances. (Even if 1m can be ensured, noise might occur if there is strong electric wave.) Additionally, equipments, television or other valuables can't be put under the unit as to avoid the condensed water of the unit from dropping into the above articles, causing damaging.

### (2) Height of Ceiling:

The ceiling should be located at the place, where the central position of air outlet port is less than 3m high above the ground.

### (3) Hoisting studs should be used during installation.

Check if the location can bear the weight of the unit. Reinforce it before installation if necessary.

### (4) The dimension of maintenance

Make sure that it is easy to demount the electrical control box, fan, motor, filter.

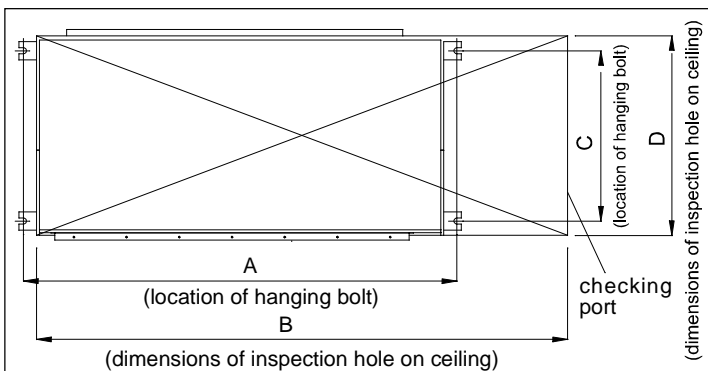
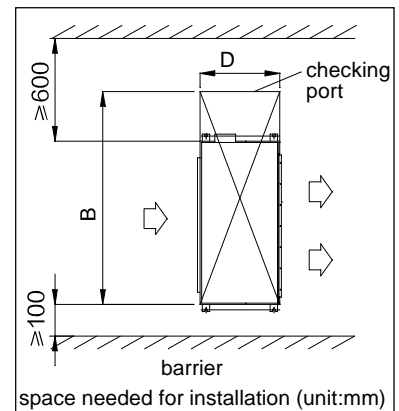

Size Model	A (mm)	B (mm)	C (mm)	D (mm)
AD072-182 MQERA	786	1100	472	635
AD242-302 MQERA	986	1300	472	635
AD362-542 MQERA	1404	1720	530	738



# Installation Procedures

## 3. Preparation before Installation

(1) Location relation between inspection hole on the ceiling and the unit and the hoisting studs (unit: mm).

Model \ Size	A (mm)	C (mm)	E (mm)	H (mm)
AD072-182 MQERA	786	472	750	695
AD242-302 MQERA	986	472	950	695
AD362-542 MQERA	1404	530	1368	798

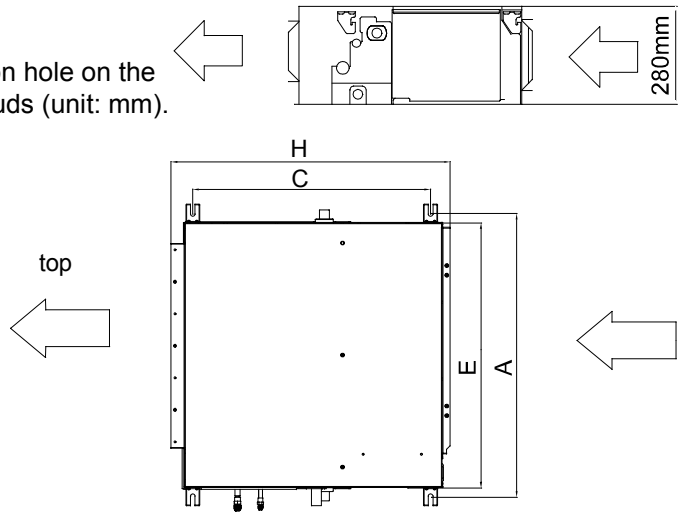

(2) If necessary, make a hole for installation and inspection on the ceiling. (used for the situation with a ceiling)

- For the size of the inspection hole on the ceiling, please refer to the above drawing.
- Before installation, finish all the preparations for all piping connected to indoor units (refrigerant, water drainage) and wiring (connection line of the line control, connection line between indoor units and outdoor unit) so that they can be connected with indoor units right after installation.
- For the inspection hole, the ceiling might be reinforced to keep the evenness of the ceiling and avoid the vibration of the ceiling. For details, please consult the construction contractor.

(3) Install the hoisting studs (M10 bolts)

In order to support the weight of the unit, use barb bolts in the situation with a ceiling. In the situation with the new ceiling, use inlaid bolts, embedded bolts or other parts provided on site. Before proceeding the installation, adjust the gap between the bolt and the ceiling.

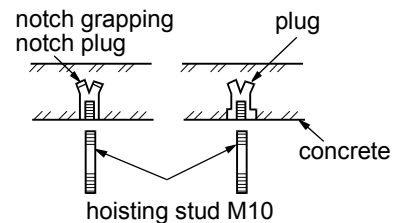

(4) Installation of Indoor Units

- Fix the indoor unit with the hoisting stud. If necessary, the machine can be hanged on the beam with bolts instead of the hoisting stud.

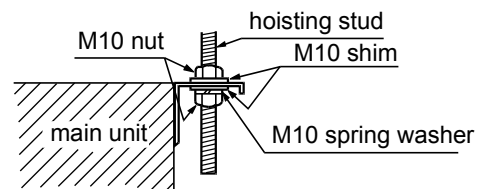

NB:

When the sizes of the main unit don't match the hole on the ceiling, regulate the slot on the hanging bracket.

### Adjusting the level

Adjust the level with a level meter or according to the following ways:

- Make the adjustment as shown in the figure.

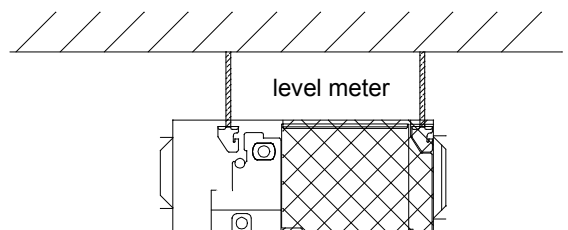

# Installation Procedures

Static Pressure Range  
unit: Pa

Static Pressure Range
0~200

## 4. Drainpipes

AD072-302MQERA

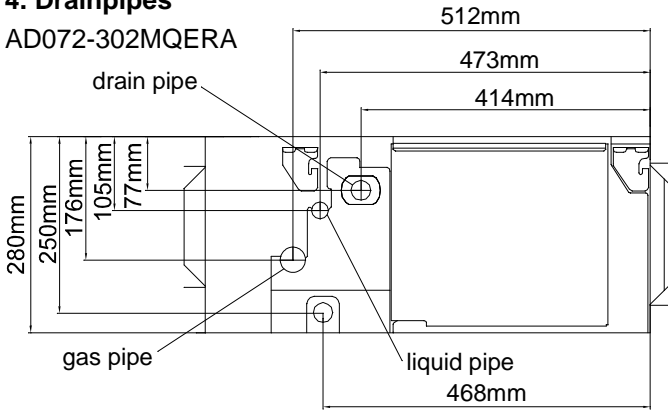

AD362-542MQERA

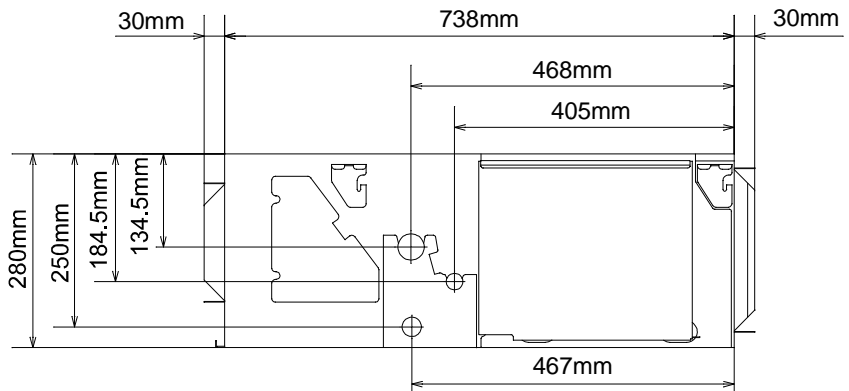

(a) Keep a gradient (1/50-1/100) of the drainpipes and avoid lobing or curving.

### • Proper Piping

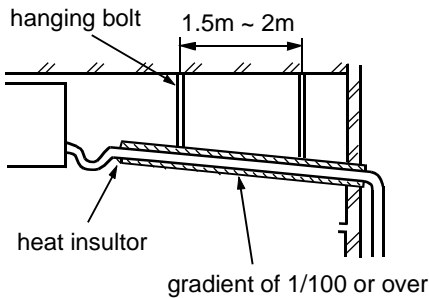

### • Improper Piping

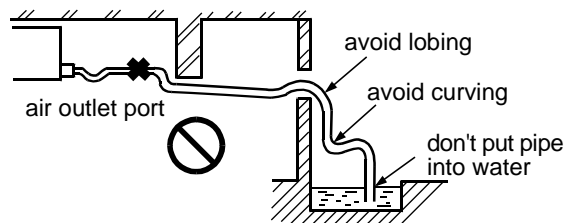

(b) When connecting the drainpipe to the equipment, don't apply too much force on one side of the equipment. Meanwhile, the piping should be positioned as close to the equipment as possible.

(c) For the drainpipe, the general purpose hard PVC tube can be purchased at local shops. During the connection, insert the end of PVC tube into the wash port and fasten it with drainage hose and thread clip. Binding agents shouldn't be used to connect the wash port and drainage hose.

# Installation Procedures

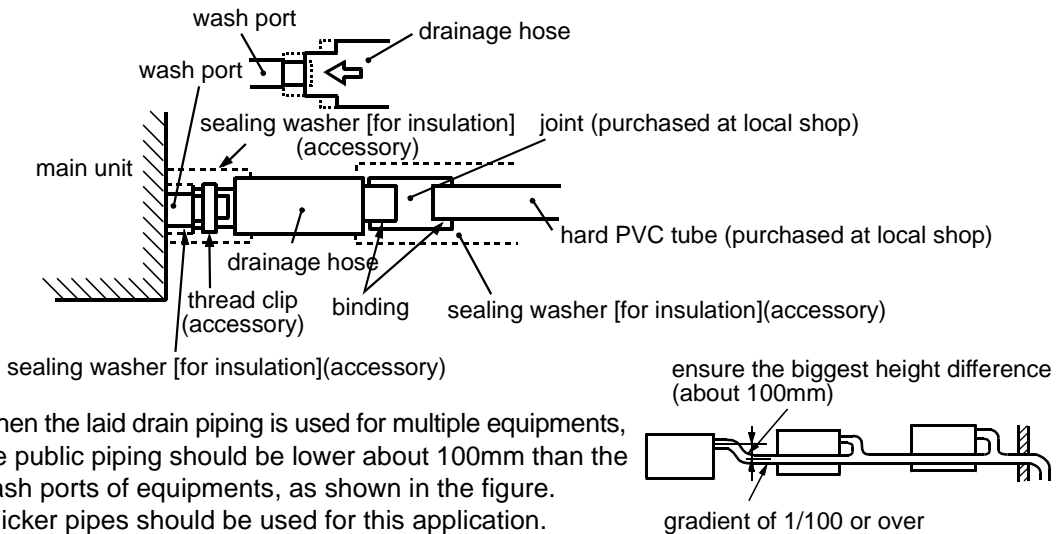

- (e) The hard PVC tube in the room must be provided with the heat insulating layer.
- (f) Don't place the drainpipes at the places where there is irritant gas. Don't put the drainpipe directly into the sewer, where there might be gases with sulfur.

(g) Backwater bend  
 Because the drainage was laied in the position of binging Subatmospheric pressure easily, gain of elevation of water in the drain pan conducesd Leakage water, for avoiding Leakage water , design a Backwater bend.  
 Configuration of Backwater bend can be cleaned, a " T " joint can be used in installing as shown as in the picture below.  
 Backwater bend was installed in the neighborhood of airconditioning  
 A backwater bend was designed in the middle of drain pipe s shown as in the picture below.

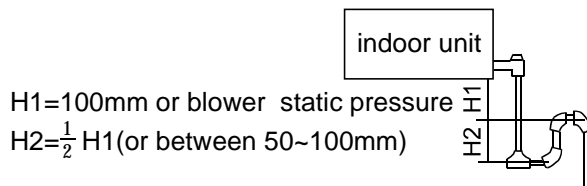

## Testing Drainage System

- (a) After finishing the electrical system, test the drainage system.
- (b) During testing, make sure that the water flow passes the piping correctly without any water leakage at the connection.
- (c) In the condition of new house, test the drainage system before fitting up the ceiling.
- (d) Even if it is installed in the season needed to heating, the testing should also be performed.

## Procedures

- (a) Provide about 1000cc of water to the equipment via air outlet port with the feed pump.
- (b) During refrigerating operation, check the drainage system..

# Installation Procedures

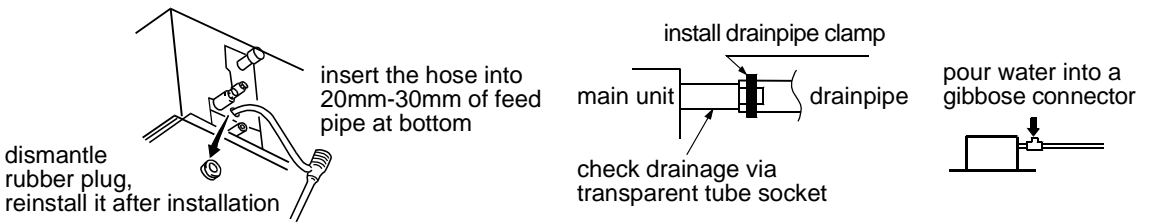

Before completing the electrical connection, a gibbose connector shall be installed on the drainpipe as to provide it with a water inlet port. Then, if any leakage exists in the piping, check it to make the water flow of the drainpipe smooth.

## 5. Installation of Air Return & Air Exhaust Pipes

For the choice and installation of air return port, air return pipe, air exhaust port and exhaust pipe, please consult service personnel of Haier company. Calculate the design chart and exterior static pressure, and select the exhaust pipe with appropriate length and shapes.

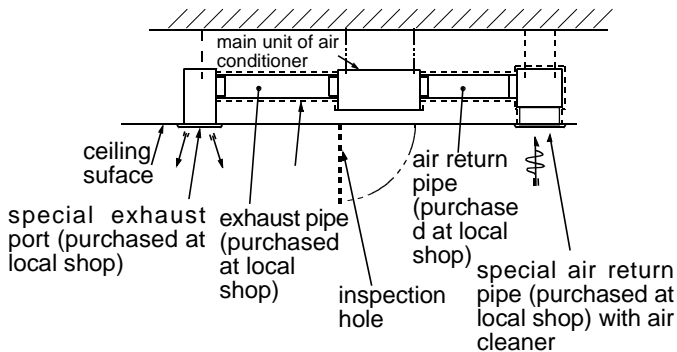

- The length difference between pipes should be limited to be less than 2:1;
- Make the piping as short as possible;
- Keep the min. elbow quantity;
- Wind the heat insulating material around the flange between the main unit and the exhaust pipe for heat insulation and sealing. Install the piping before fitting up the ceiling.
- At least 2 meters air duct is needed at air inlet and air outlet.
- Flexible connection is needed between indoor units and air duct.
- ESP should be lower than 200 Pa.

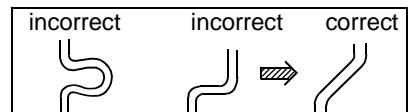

## 6. Cautions in Installation of Air Return Pipe & Exhaust Pipe

- It is recommended to use the blast pipes, which can be anti-condensation and absorb sound. (purchased at local shops)
- Complete the installation of the blast pipes before fitting up the suspended ceiling.
- Heat insulation should be made for the blast pipes.
- The special exhaust port should be arranged at the place where the air is distributed evenly.
- An inspection hole should be left on the surface of the ceiling for future maintenance.

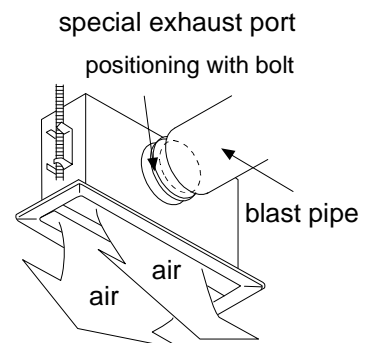

# Installation Procedures

## 7.Connection of return air duct (setting back air return opening when leaving factory)

Remarks:

In installation, you can select the lower air return or back air return by adjusting the location of air inlet frame. Air return from bottom will influence the unit noise, so we suggest use rear return installation.

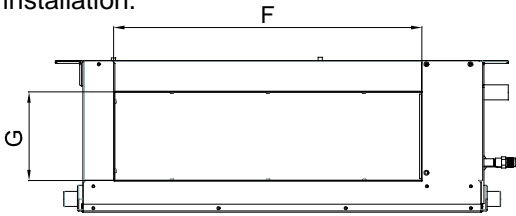

Model	Size	F (mm)	G (mm)
AD072-182MQERA		660	200
AD242-302MQERA		740	200
AD362-542MQERA		1280	235

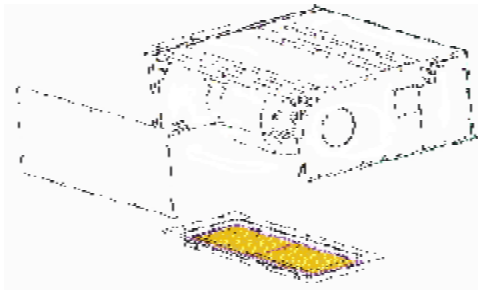

back air return opening

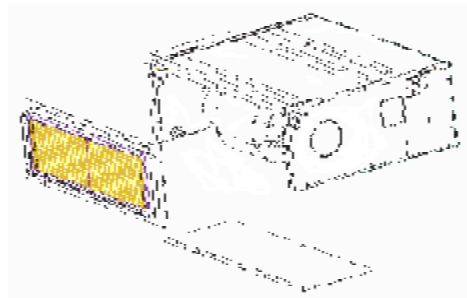

below air return opening

## 8.Concatenation means of exchanging flesh air

(1) Cut away the nummular component of lateral board

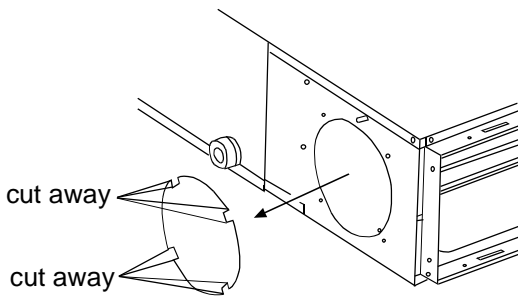

(2) Install the nummular air pipe (air pipe can be purchased in local district)

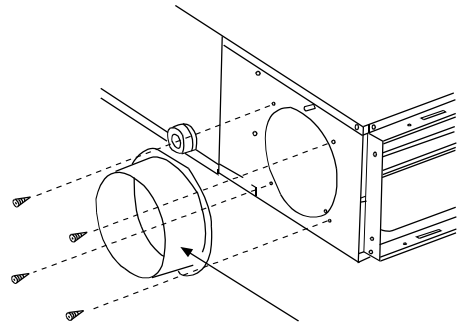

(3) Airproof the joint by airproof cingulum avoiding

nummular air pipe

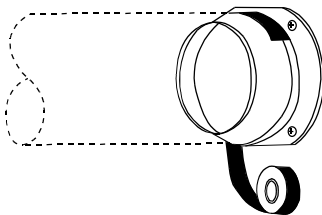

# Installation Procedures

## 9. Install outlet flange

Install outlet flange basising the needs, the outlet flange is standard component, bolts are laied in accessories box.

Note: You can select not to connect with the flange. Instead of it, you can use the round plastic air outlet (purchased by user)

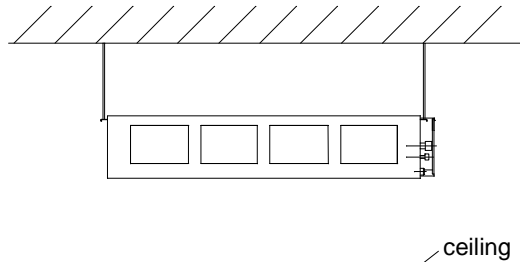

## 10. Examples for Bad Installation

- The unit is not equipped with the air return pipe and the inner side of the suspending ceiling is used as the blast pipe, causing the humidity increasing due to irregular air mass, strong wind or sunlight from the outside world.
- There might be condensate dropping down at the outer side of the blast pipe. The humidity is high, even if the inner side of the suspended ceiling isn't used as a blast pipe in new concrete buildings. At this time, the whole body should use the thermo wool for heat preservation (the thermo wool can be packed with a steel wire).
- It is operated under the conditions beyond the limits, leading to the overload of the compressor.
- Affected by the capacity of the exhaust fan, and the strong wind and wind direction in the outer flue, when the blowing quantity of the air conditioner exceeds the limits, the drained water of the heat exchanger will overflow, causing water leakage.

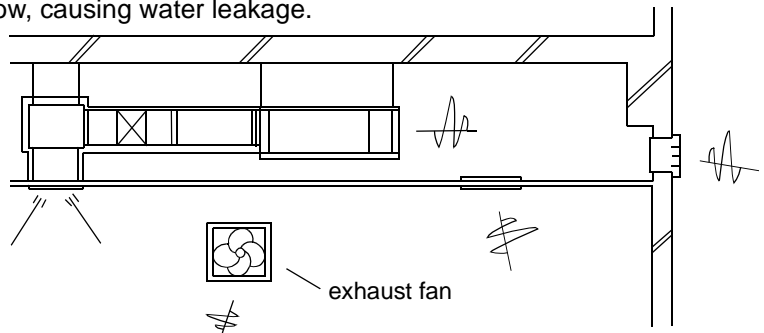

example of bad installation

## 11. Static Pressure GradeSetting

For AD362~542MQERA units, after installation need to preliminary estimates external static pressure, according to the external static pressuresetting the unit's static pressure grade by controller.

Note: the detail operation methods for setting the unit's static pressure grade refer to the controller manual.

## 12. Refrigerant Tube

Ⓜ Tubing Permissible Length & Height Difference

Please refer to the attached manual of outdoor units.

Ⓜ Piping Materials & Heat Insulating Materials

As to prevent condensation, heat insulating treatment should be performed. The heat insulating treatment for gas and liquid piping should be done respectively.

The static pressure range of each gradeas follows:

Grade	Static pressure range
1	0~25pa
2	25~75pa
3	75~125pa
4	125~175pa
5	175~200pa

Piping Material	Hard PVC tube VP25mm(inner bore)
Heat Insulating Material	Vesicant polythene thickness: over 7mm

# Installation Procedures

## Tubing Materials & Specifications

Model		AD072~092MQERA	AD122~182MQERA	AD242~542MQERA
Tubing Size (mm)	Gas pipe	Ø9.52	Ø12.7	Ø15.88
	Liquid pipe	Ø6.35	Ø6.35	Ø9.52
Tubing Material		Phosphor deoxybronze seamless pipe (TP <sub>2</sub> ) for air conditioner		

## Refrigerant Filling Amount

Add the refrigerant according to the installation instruction of outdoor unit. The addition of R410A refrigerant must be performed with a measure gage to ensure the specified amount or compressor failure can be caused by filling too much or little refrigerant.

## Connecting Procedures of Refrigerant Tubing

Proceed the flare tube connecting operation to connect all the refrigerant tubes.

- Dual wrenches must be used in the connection of indoor unit tubing.
- Mounting torque refers to the right table

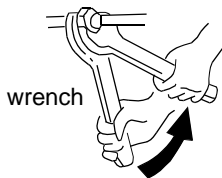

Outer Diameter of Tubing (mm)	Mounting Torque
Ø6.35	11.8~13.7N.m
Ø9.52	32.7~39.9N.m
Ø12.7	49.0~53.9N.m
Ø15.88	78.4~98.0N.m
Ø19.05	97.2~118.6N.m

## Cutting and Enlarging

Cutting or enlarging pipes should be proceeded by installation personnel according to the operating criterion if the tube is too long or flare opening is broken.

## Vacuumizing

Vacuumize from the stop valve of outdoor units with vacuum pump. Refrigerant sealed in indoor machine is not allowed to use for vacuumization.

## Open All Valves

Open all the valves of outdoor units. [NB: oil balancing stop valve must be shut up completely when connected one main unit.]

## Checkup for Air Leakage

Check if there is any leakage at the connecting part and bonnet with hydrophone or soapsuds.

## Connecting

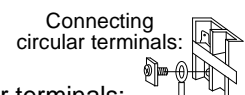

1. Connecting circular terminals:  
The connecting method of circular terminal is shown in the Fig. Take off the screw, connect it to the terminal tier after heading it through the ring at the end of the lead and then tighten it.
2. Connecting straight terminals:  
The connection methods for the circular terminals are shown as follows: loosen the screw before putting the line terminal into the terminal tier, tighten the screw and confirm it has been clamped by pulling the line gently.
3. Pressing connecting line  
After connecting line is completed, press the connecting line with clips which should press on the protective sleeve of the connecting line.

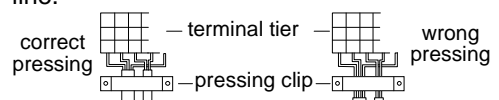

# Electrical Wiring

## ⚠ Warning

- Electrical construction should be made with specific mains circuit by the qualified personnel according to the installation instruction. Electric shock and fire may be caused if the capacity of power supply is not sufficient. **!**
- During arranging the wiring layout, specified cables should be used as the mains line, which accords with the local regulations on wiring. Connecting and fastening should be performed reliably to avoid the external force of cables from transmitting to the terminals. Improper connection or fastness may lead to burning or fire accidents. **!**
- There must be the ground connection according to the criterion. Unreliable grounding may cause electrical shocks. Do not connect the grounding line to the gas pipe, water pipe, lightning rod and telephone line. **!**

## ⚠ Attention

- Only copper wire can be used. Breaker for electric leakage should be provided, or electric shock may occur.
- The wiring of the mains line is of Y type. The power plug L should be connected to the live wire and plug N connected to null wire while ⊕ should be connected to the ground wire. For the type with auxiliary electrically heating function, the live wire and the null wire should not be misconnected, or the surface of electrical heating body will be electrified. If the power line is damaged, replace it by the professional personnel of the manufacturer or service center.
- The power line of indoor units should be arranged according to the installation instruction of indoor units.
- The electrical wiring should be out of contact with the high-temperature sections of tubing as to avoid melting the insulating layer of cables, which may cause accidents.
- After connected to the terminal tier, the tubing should be curved into be a U-type elbow and fastened with the pressing clip.
- Controller wiring and refrigerant tubing can be arranged and fixed together. **!**
- The machine can't be powered on before electrical operation. Maintenance should be done while the power is shut down.
- Seal the thread hole with heat insulating materials to avoid condensation.
- Signal line and power line are separately independent, which can't share one line. [Note: the power line, signal line are provided by users. Parameters for power lines are shown as below:  $3 \times (1.0-1.5) \text{ mm}^2$ ; parameters for signal line:  $2 \times (0.75-1.25) \text{ mm}^2$  ( shielded line)]
- 5 butt lines (1.5mm) are equipped in the machine before delivery, which are used in connection between the valve box and the electrical system of the machine. The detailed connection is displayed in the circuit diagram.

Supply Wiring Drawing

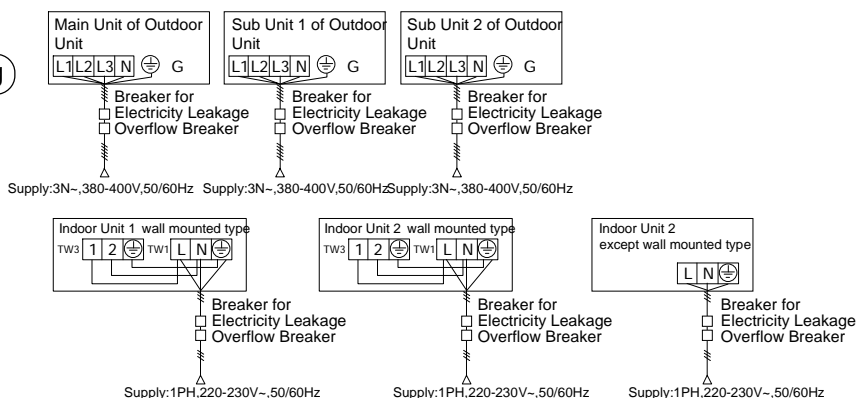

- Indoor units and outdoor units should be connected to the power source separately. Indoor units must share one single electrical source, but its capacity and specifications should be calculated. Indoor & outdoor units should be equipped with the power leakage breaker and the overflow breaker.



# Electrical Wiring

## Signal Wiring Drawing

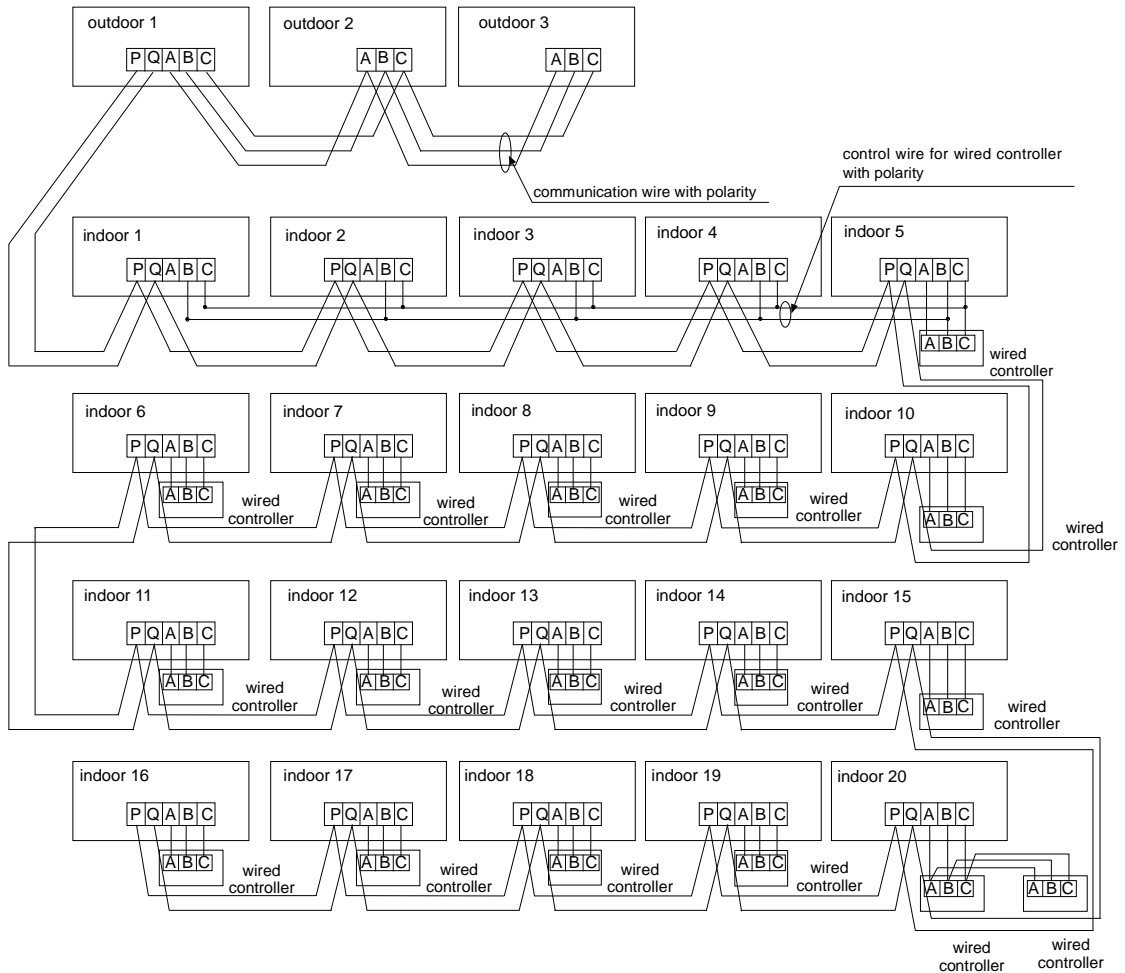

Outdoor units are of parallel connection via three lines with polarity. The main unit, central control and all indoor units are of parallel connection via two lines without polarity.

There are three connecting ways between line control and indoor units:

A. One line control controls multiple units, i.e. 8 indoor units, as shown in the above figure, (1-5 indoor units).

The indoor unit 5 is the line-controlled main unit and others are the ine-controlled sub units. The remoter control and the main unit (directly connected to the indoor unit of line control) are connected via three lines with polarity. Other indoor units and the main unit are connected via two lines with polarity. SW01 on the main unit of line control is set to 0 while SW01 on other sub units of line control are set to 1, 2, 3 and so on in turn.

B. One line control controls one indoor unit, as shown in the above figure(indoor unit 6-19). The indoor unit and the line control are connected via three lines with polarity.

C. Two line controls control one indoor unit, as shown in the figure (indoor unit 20). Either of the line controls can be set to be the master line control while the other is set to be the auxiliary line control. The master line control and indoor units, and the master and auxiliary line controls are connected via three lines with polarity.

When the indoor units are controlled by the remote control, switch over the modes by Switching Mode of Line-Controlled Main Unit/ Line-Controlled Sub Units/ Remote-Controlled Types. The signal terminals needn't to be equipped with wires and connected to the line control.

# Electrical Wiring

Indoor power supply wiring & signal wiring between indoor and outdoor & signal wiring between indoors.

Total Current of Indoor Units(A)	Items	Cross Section (mm <sup>2</sup> )	Length (m)	Rated Current of Overflow Breaker(A)	Rated current of residual Circuit Breaker(A) Ground Fault Interruptor(mA) Response time(S)	Cross Sectional Area of Signal Line	
						Outdoor -indoor (mm <sup>2</sup> )	Indoor -indoor (mm <sup>2</sup> )
<7		2.5	20	10	10 A,30 mA,0.1S or below		
≥7 and <11		4	20	16	16 A,30 mA,0.1S or below	2 cores×0.75-2.0 mm <sup>2</sup> shielded lin	
≥11and <16		6	25	20	20 A,30 mA,0.1S or below		
≥16 and <22		8	30	32	32 A,30 mA,0.1S or below		
≥22 and <27		10	40	32	32 A,30 mA,0.1S or below		

- The electrical power line and signal lines must be fastened tightly.
- Every indoor unit must have the ground connection.
- The power line should be enlarged if it exceeds the permissible length.
- Shielded lays of all the indoor and outdoor units should be connected together, with the shielded lay at the side of signal lines of outdoor units grounded at one point.
- It is not permissible if the whole length of signal line exceeds 1000m.

## Signal Wiring of Wired controller

Length of Signal Line (m)	Wiring Dimensions	Length of Signal Line (m)	Wiring Dimensions
<100	0.3mm <sup>2</sup> x core shielding lin	≥300 and <400	1.25mm <sup>2</sup> x core shielding lin
≥100 and <200	0.5mm <sup>2</sup> x core shielding lin	≥400 and <600	2 mm2x core shielding lin
≥200and <300	0.75mm <sup>2</sup> x core shielding lin		

- The shielding lay of the signal line must be grounded at one end.
- The total length of the signal line shall not be more than 600m.

# Electrical Wiring

## Dipswitch Setting

• The dipswitch is dialed to "ON" position with the overline at the state of strapping if the code or overline status is "1" The dipswitch is dialed to "OFF" position with the overline at the state of disconnection if the code or overline status is "0"

• In the table below, the choice in the box "□" refers to the setting of the socket/overline before delivery.

### Indoor Units PCB

In the following table, 1 represents ON and 0 represents OFF.

Definition principles of code switches:

SW01 is used to set capabilities of master and slave indoor units as well as indoor unit; SW03 is used to set indoor unit address (combine original communication address and address of centralized controller); SW08 is used set room card and 26°C lock.

(A) Definition and description of SW01

SW01_1	Operation mode displayed on wired controller	1	[air supply] [refrigerating] [dehumidification]			
		0	[automatic] [air supply] [refrigerating] [dehumidification] [heating]			
SW01_2 SW01_3 SW01_4	Address of wire controlled indoor unit (Note 1)	[2]	[3]	[4]	Address of wire controlled indoor unit (group address)	
		0	0	0	0# (wire controlled master unit) (default)	
		0	0	1	1# (wire controlled slave unit)	
		0	1	0	2# (wire controlled slave unit)	
		0	1	1	3# (wire controlled slave unit)	
		1	0	0	4# (wire controlled slave unit)	
		1	0	1	5# (wire controlled slave unit)	
		1	1	0	6# (wire controlled slave unit)	
SW01_5 SW01_6 SW01_7 SW01_8	Capability of indoor unit	[5]	[6]	[7]	[8]	Capability of indoor unit
		0	0	0	0	0.6HP
		0	0	0	1	0.8HP
		0	0	1	0	1.0HP
		0	0	1	1	1.2HP
		0	1	0	0	1.5HP
		0	1	0	1	1.7HP
		0	1	1	0	2.0HP
		0	1	1	1	2.5HP
		1	0	0	0	3.0HP
		1	0	0	1	3.2HP
		1	0	1	0	4.0HP
		1	0	1	1	5.0HP
		1	1	0	0	6.0HP
		1	1	0	1	8.0HP
		1	1	1	0	10.0HP
1	1	1	1	15.0HP		

Note 1: A wired controller can be connected to at most eight ultrathin air-duct indoor units.

# Electrical Wiring

## (B) Definition and description of SW03

SW03_1	Address setting mode	[1]	Address setting mode								
		0	Automatic setting (default)								
		1	Code-set address								
SW03_2 ~ SW03_8	Code-set indoor unit address and centralized controller address (Note 2)	[2]	[3]	[4]	[5]	[6]	[7]	[8]	Address of indoor unit	Address of centralized controller	
		0	0	0	0	0	0	0	0	0# (Default)	0# (Default)
		0	0	0	0	0	0	0	1	1#	1#
		0	0	0	0	0	0	1	0	2#	2#
		...	...	...	...	...	...	...	...	...	...
		0	1	1	1	1	1	1	1	63#	63#
		1	0	0	0	0	0	0	0	0#	64#
		1	0	0	0	0	0	0	1	1#	65#
		1	0	0	0	0	0	1	0	2#	66#
		...	...	...	...	...	...	...	...	...	...
		1	1	1	1	1	1	1	1	63#	127#

### Note 2:

- Set the address by code when connecting the centralized controller or gateway or charge system.
- Address of centralized controller =communication address + 0 or +64.
- SW03\_2=OFF, address of centralized controller =communication address+0=communication address
- SW03\_2=ON, address of centralized controller=communication address+64 (applies when centralized controller is used and there are more than 64 indoor units)
- To use with 0010451181A in use, it is required to use code for address setting. Set SW03\_1=0N and SW03\_2=OFF; SW03\_3, SW03\_4, SW03\_5, SW03\_6, SW03\_7 and SW03\_8 are address codes which are set according to actual address.
- Address setting function of wired controller for ultrathin card machine is disabled.

## (C) Jumper definition description

Electronic expansion valve PMV manual control settings(CN27, CN29)

Manually fully open CN27: short circuit CN27 for 2 seconds after power, the PMV fully opened.

Manually fully close CN29: short circuit CN29 for 2 seconds after power, the PMV fully closed.

26°C Lock function Activation:

Default: Deactivated

Activation: Press "Health" button on remote controller 8 times in 5 seconds, and you hear 4 times beep, then activate the function.

Deactivation: Press "Health" button on remote controller 8 times in 5 seconds, and you hear 2 times beep, then deactivate the function.

# Electrical Wiring

## Code setting of wired controller

### Function switches

Code	Switch status	Function description	Default setting	Remarks	
SW1	ON	Auxiliary wired controller	OFF		
	OFF	Master wired controller			
SW2	ON	Common wired controller	ON		
	OFF	New fan-only has refrigerating, heating, and air supplying modes			
SW3	ON	Display ambient temperature	OFF		
	OFF	Do not display ambient temperature			
SW4	ON	26°C lock disabled	ON		
	OFF	26°C lock enabled			
SW5	ON	Collect ambient temperature of wired controller	ON		
	OFF	Collect ambient temperature of PCB			
SW6	ON	Power failure memory disabled	OFF		
	OFF	Power failure memor enabled			
SW7	ON	Temperature sensor 4k7 enabled	ON		Betewwn SW7 and SW8, one and only one must be ON for any given period
	OFF	Temperature sensor 4k7 disabled			
SW8	ON	Temperature sensor 5k1 enabled	OFF		
	OFF	Temperature sensor 5k1 disabled			

Note: ON indicates short circuit; OFF indicates disconnection.

### The difference between master and slave wired controller

Topic	Master controller	Slave controller
Function	All function	ON/OFF, Mode, Fan speed, Temp, Swing function only.

# Test Run & Fault Code

## Before Test Run

- Before switching it on, test the supply terminal tier (L, N terminals) and grounding points with 500V megaohm meter and check if the resistance is above 1MΩ. It can't be operated if it is below 1MΩ.
- Connect it to the power supply of outdoor units to energize the heating belt of the compressor. To protect the compressor at startup, power it on 12 hours prior to the operation.

### Check if the arrangements of the drainpipe and connection line are correct.

The drainpipe shall be placed at the lower part while the connection line placed at the upper part. Heat preservation measures should be taken such as winding the drainpipe esp. in the indoor units with heating insulating materials.

The drain pipe should be made a slope type to avoid protruding at the upper part and concaving at the lower part on the way.

## Checkup of Installation

- |   |  |
|---|--|
| <input type="checkbox"/> check if the mains voltage is matching   | <input type="checkbox"/> check if the installation place meets the requirement |
| <input type="checkbox"/> check if there is air leakage at the piping joints                             | <input type="checkbox"/> check if there is too much noise                      |
| <input type="checkbox"/> check if the connections of mains power and indoor & outdoor units are correct | <input type="checkbox"/> check if the connecting line is fastened              |
| <input type="checkbox"/> check if the serial numbers of terminals are matching                          | <input type="checkbox"/> check if the connectors for tubing are heat insulated |
|   | <input type="checkbox"/> check if the water is drained to the outside          |
|   | <input type="checkbox"/> check if the indoor units are positioned              |

## Ways of Test Run

Do ask the installation personnel to make a test run. Take the testing procedures according to the manual and check if the temperature regulator works properly.

When the machine fails to start due to the room temperature, the following procedures can be taken to do the compulsive running. The function is not provided for the type with remote control.

- Set the wired controller to refrigerating/heating mode, press "ON/OFF" button for 5 seconds to enter into the compulsive refrigerating/heating mode. Repress "ON/OFF" button to quit the compulsive running and stop the operation of the air conditioner.

## Fault Remedies

When any fault appears, consult the fault code of line control or the flashing times for LED5 of computer panel of indoor units/health lamp of receiving window of remote control and find out the faults as shown in the following table to remove all faults.

### Indoor Unit Faults

Failure code at wired controller	PCB LED5(Indoor Units)/ Receiver Timer Lamp(Remote Controller)	Fault Descriptions
01	1	Fault of indoor unit ambient temp. transducer TA
02	2	Fault of indoor unit pipe temp. transducer TC1
03	3	Fault of indoor unit pipe temp. transducer TC2
04	4	Fault of indoor unit dual heat source temp. transducer
05	5	Fault of indoor unit EEPROM
06	6	Fault of communication between indoor & outdoor units
07	7	Fault of communication between indoor unit and wired control
08	8	Fault of indoor unit float switch
09	9	Fault of duplicate indoor unit address
12	12	Fault of indoor unit 50Hz Zero-crossing
13	13	DC Motor Match(AD*MQERA)
14	14	Fault of indoor unit DC motor
16	16	DC Motor Communication(AD*MQERA)
18	18	BS valve box or 4WV switch failure
20	20	Corresponding faults of outdoor units



Qingdao Haier Air Conditioner Electric Co.,Ltd.

Haier Industrial Park,Qianwangang Road,Eco-Tech Development Zone,  
Qingdao 266555,Shandong,P.R.C.